



Hand pliers for blind nuts

359-20-N

SAM Outillage

10 rue Camille de Rochetaillée
42000 Saint-Etienne - France

RCS Saint-Etienne B 338 002 231 | SAS au capital de 8 189 583 €

<https://www.sam-outillage.com/>

Photos and texts not contractually binding. Do not litter. Document generated on 2024-05-03 15:04:08





DESCRIPTION

Hand pliers for blind nuts

Capacity: M3 to M6 for aluminium and steel nuts, M3 to M5 for stainless steel nuts. Supplied with anvils and threaded rods M3 to M6 and tightening wrench. Bushing for holding in closed position. Return spring to facilitate rivet installation. Set screw for adjusting the threaded rod. Threaded rods held by balls. Set screw for adjusting the stroke.

SPECIFIC DATA

SAM Outillage

10 rue Camille de Rochetaillée
42000 Saint-Etienne - France

RCS Saint-Etienne B 338 002 231 | SAS au capital de 8 189 583 €

<https://www.sam-outillage.com/>

Photos and texts not contractually binding. Do not litter. Document generated on 2024-05-03 15:04:08



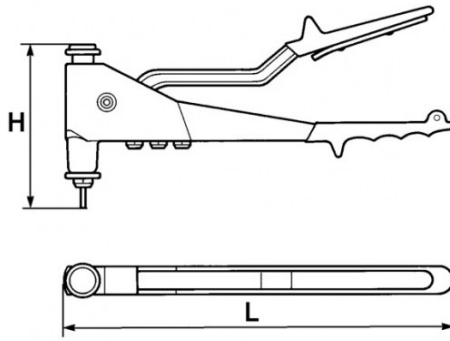

Designation	MANUAL BLIND-NUT PLIERS
Sales reference	359-20-N
L (mm)	250
Weight (g)	600
H (mm)	120
Minimum openings (mm)	70
Maximum openings (mm)	140
Aluminium rivet maximum diameter mm	6
Steel rivet maximum diameter mm	6
Stainless steel rivet maximum diameter mm	5
Copper rivet maximum diameter mm	-
Guarantee	O SAM TOOL guarantee.

Guarantee applied

O | SAM TOOL guarantee.

Guarantee without time limit on the tools used under normal conditions.

[>> Find out more](#)

SAM Outillage

10 rue Camille de Rochetaillée
42000 Saint-Etienne - France

RCS Saint-Etienne B 338 002 231 | SAS au capital de 8 189 583 €

<https://www.sam-outillage.com/>

Photos and texts not contractually binding. Do not litter. Document generated on 2024-05-03 15:04:08

